

LA 17PS

LA 22PS

LA 26PS

Dimplex

**Montage- und
Gebrauchsanweisung**

Deutsch

**Installation and
Operating Instructions**

English

**Instructions d'installation
et d'utilisation**

Français

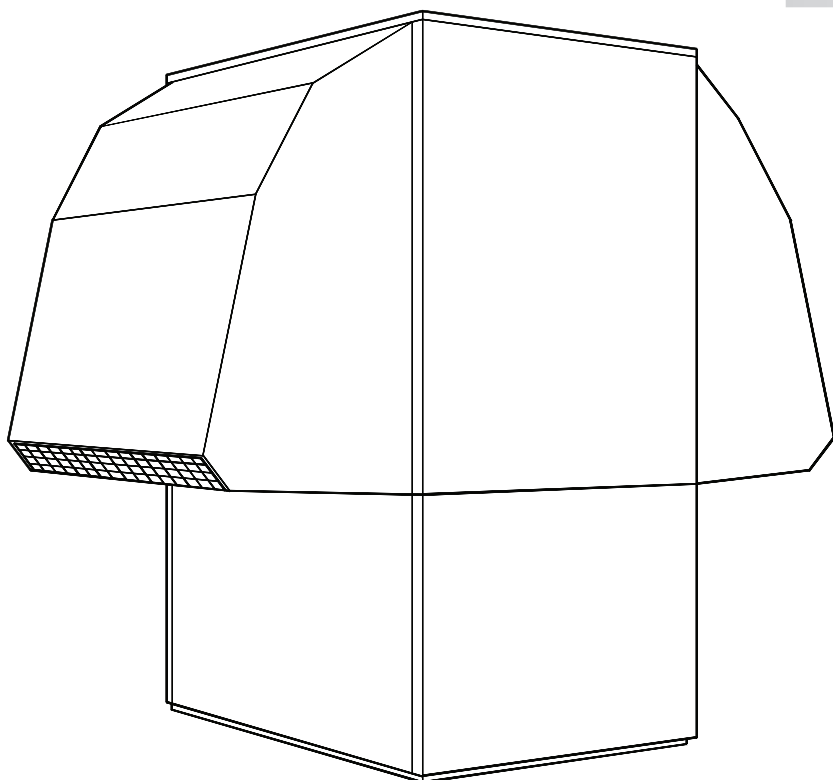

**Luft/Wasser-
Wärmepumpe für
Außenaufstellung**

**Air-to-Water Heat
Pump for Outdoor
Installation**

**Pompe à chaleur
air-eau pour
installation
extérieure**

Table of contents

1	Please Read Immediately	E-2
1.1	Important Information.....	E-2
1.2	Legal Regulations and Directives	E-2
1.3	Energy-Efficient Use of the Heat Pump	E-2
2	Purpose of the Heat Pump	E-3
2.1	Application	E-3
2.2	Operating Principle	E-3
3	Scope of Delivery	E-3
3.1	Basic Device	E-3
3.2	Switch Box	E-4
3.3	Heat Pump Controller	E-4
4	Transport	E-4
5	Set-up	E-5
5.1	General Information	E-5
5.2	Condensed Water Pipe.....	E-5
6	Installation	E-5
6.1	General Information	E-5
6.2	Heating System Connection	E-5
6.3	Electrical Connection	E-6
7	Start-up	E-6
7.1	General Information	E-6
7.2	Preparation	E-6
7.3	Procedure	E-6
8	Maintenance / Cleaning	E-7
8.1	Maintenance	E-7
8.2	Cleaning the Heating System	E-7
8.3	Cleaning the Air System	E-8
9	Faults / Trouble-Shooting	E-8
10	Decommissioning/Disposal	E-8
11	Device Information	E-9
	Anhang / Appendix / Annexes	A-I

1 Please Read Immediately

1.1 Important Information

⚠ ATTENTION!

Any work on the heat pump may only be performed by authorised and qualified after-sales service technicians.

⚠ ATTENTION!

The device is not suitable for operation with a frequency converter.

⚠ ATTENTION!

Never install the device in rooms in which there are any permanent ignition sources.

⚠ ATTENTION!

When transporting the heat pump, ensure that it is not tilted more than 45° (in any direction).

⚠ ATTENTION!

The heat pump and transport pallet are only joined by the packing film.

⚠ ATTENTION!

Do not restrict or block the area around the air intake or outlet.

⚠ ATTENTION!

Ensure that there is a clockwise rotating field: Operating the compressor in the wrong rotational direction could cause damage to the compressor.

⚠ ATTENTION!

Never use cleaning agents containing sand, soda, acid or chloride as these can damage the surfaces.

⚠ ATTENTION!

We recommend the installation of a suitable corrosion protection system to prevent the formation of deposits (e.g. rust) in the condenser of the heat pump.

⚠ ATTENTION!

The refrigerating circuit may not be damaged in any way.

⚠ ATTENTION!

Before opening the device, ensure that all circuits are isolated from the power supply.

1.2 Legal Regulations and Directives

The construction and design of the heat pump complies with all relevant EU directives, DIN/VDE regulations (see CE declaration of conformity).

The relevant VDE, EN and IEC standards must be adhered to when connecting the heat pump to the power supply or carrying out maintenance work. Any further connection requirements stipulated by local utility companies must also be observed.

When connecting the heating system, all applicable regulations must also be adhered to.

⚠ ATTENTION!

Any work on the heat pump may only be performed by authorised and qualified after-sales service technicians.

Persons, especially children, who are not capable of operating the device safely due to their physical, sensory or mental abilities or their inexperience or lack of knowledge, must not operate this device without supervision or instruction by the person in charge.

Children must be supervised to ensure that they do not play with the device.

1.3 Energy-Efficient Use of the Heat Pump

With the purchase of this heat pump you are helping to protect the environment. A prerequisite for energy-efficient operation is the correct design of the heat source system and heating system (radiators and circulation pump).

It is particularly important for the efficiency of a heat pump to keep the temperature difference between heating water and heat source as small as possible. For this reason, it is advisable to design the heat source and heating system very carefully. **A temperature difference of approx. one Kelvin increases the power consumption by around 2.5%.** When designing the heating system, it should be borne in mind that special consumers such as e.g. domestic hot water preparation should also be taken into consideration and dimensioned for low temperatures. **Underfloor heating systems (panel heating)** are optimally suited for heat pump use on account of the low flow temperatures (30 °C to 40 °C).

It is important to ensure that the heat exchangers are not contaminated during operation because this increases the temperature difference, in turn reducing the COP.

Correct adjustment of the heat pump controller is also important for energy-efficient use of the heat pump. Further information can be found in the heat pump controller's operating instructions.

2 Purpose of the Heat Pump

2.1 Application

The air-to-water heat pump is designed for use in existing or newly built heating systems.

It is designed exclusively for heating domestic hot water and heating water!

The heat pump is suitable for mono energy and bivalent operation down to an external temperature of -20 °C.

Proper defrosting of the evaporator is guaranteed by maintaining a heating water return flow temperature of more than 13 °C during continuous operation.

The heat pump is not designed for the increased heat consumption required when a building is being dried out. The additional heat consumption should be met using special devices provided by the customer. If a building is to be dried out in autumn or winter, we recommend installing an additional heating element (available as an accessory).

⚠ ATTENTION!

The device is not suitable for operation with a frequency converter.

2.2 Operating Principle

Surrounding air is drawn in by the ventilator and fed via the evaporator (heat exchanger). The evaporator cools the air, i.e. it extracts heat from it. This extracted heat is then transferred to the working medium (refrigerant) in the evaporator.

The heat is "pumped" to a higher temperature level by increasing its pressure with the aid of the electrically driven compressors. It is then transferred to the heating water using the liquifier (heat exchanger).

Electrical energy is used to raise the temperature of the heat in the environment to a higher level. Because the energy extracted from the air is transferred to the heating water, this type of device is called an air-to-water heat pump.

The air-to-water heat pump consists of the main components evaporator, ventilator and expansion valve, as well as the low-noise compressors, liquifier and electrical control system.

At low ambient temperatures, humidity accumulates on the evaporator in the form of frost reducing the transfer of heat. The evaporator is defrosted automatically by the heat pump as required. Steam may be emitted from the air outlet depending on the atmospheric conditions.

3 Scope of Delivery

3.1 Basic Device

The heat pump is of compact design and is supplied complete with the components listed below.

R290 (propane) is used as refrigerant.

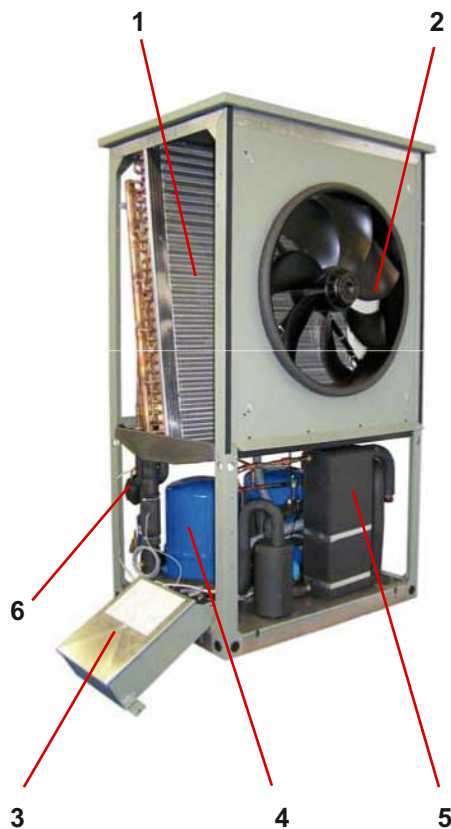

- 1) Evaporator
- 2) Ventilator
- 3) Switch box
- 4) Compressor
- 5) Liquifier
- 6) Expansion valve

3.2 Switch Box

The switch box is located in the heat pump. All electrical components are accessible after the front cover and the switch box cover have been removed.

The switch box contains the supply connection terminals, the plug connector for the control line, as well as the power contactors and the soft starter unit.

3.3 Heat Pump Controller

Use the heat pump controller included in the scope of supply to operate the air-to-water heat pump.

The heat pump controller is a convenient electronic regulation and control device. It controls and monitors the entire heating system on the basis of the external temperature, including domestic hot water preparation and safety systems.

The customer must install the return temperature sensor and the external temperature sensor, which are supplied with the heat pump controller / with these instructions together with the necessary fixing accessories.

The enclosed operating instructions describe the function and use of the heat pump controller.

4 Transport

⚠ ATTENTION!

Never install the device in rooms in which there are any permanent ignition sources.

⚠ ATTENTION!

When transporting the heat pump, ensure that it is not tilted more than 45° (in any direction).

Use a wooden pallet for transporting the heat pump to the final installation location. The basic device can be transported with a lift truck, hand truck or by means of 3/4" pipes fed through the holes in the base plate or frame.

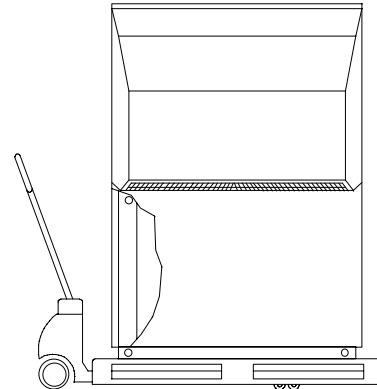

⚠ ATTENTION!

The heat pump and transport pallet are only joined by the packing film.

Before using the transport holes in the frame, it is necessary to remove the lower side panel assemblies. This is done by loosening each of the two screws at the base and then withdrawing the panels by unhooking them from above. Rehang the panels by gently pushing them in an upwards direction.

Be careful not to damage any components when inserting the pipes through the frame.

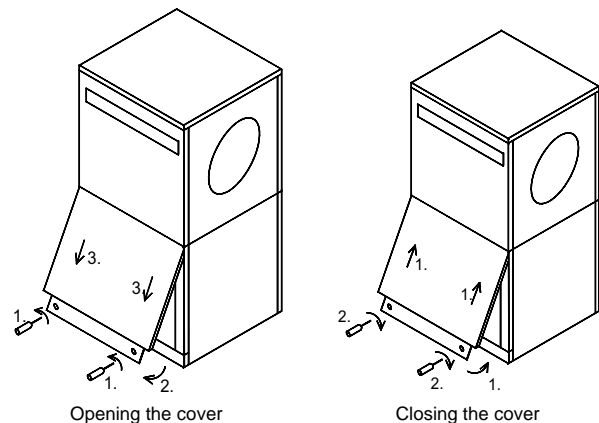

5 Set-up

5.1 General Information

The heat pump is suited for outdoor installation. The device should always be installed on a permanently smooth, even and horizontal surface and must be aligned vertically. The entire frame should lie directly on the ground to ensure a good sound-proof seal and to prevent the water-bearing components from becoming too cold. If this is not the case, additional insulation measures may be necessary. It must be possible to carry out maintenance work without hindrance. This can be ensured by maintaining a clearance of 1.2 m to any fixed walls.

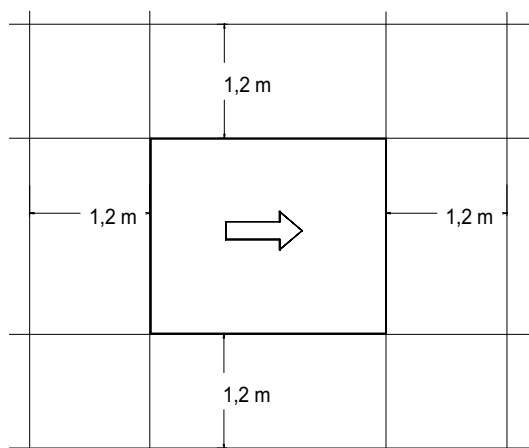

⚠ ATTENTION!

Do not restrict or block the area around the air intake or outlet.

5.2 Condensed Water Pipe

Condensed water that forms during operation must be drained off frost-free. The heat pump must be mounted on a level plane to guarantee proper drainage. The condensed water pipe must have a minimum diameter of 50 mm and should be fed frost-free into a sewer. Condensate should not be discharged directly into clearing tanks and cesspits because the aggressive vapours could destroy the evaporator.

6 Installation

6.1 General Information

The following connections need to be established on the heat pump:

- Flow and return flow of the heating system
- Condensate outflow
- Control line to the heat pump controller
- Power supply

6.2 Heating System Connection

The heating system connections on the heat pump have a 1 1/4" external thread.

Route the connection hoses out of the device in a downwards direction. Use a spanner to firmly grip the transitions when connecting the heat pump. After the heat pump has been installed, the ductwork must be sealed so that the connection is gastight.

Before connecting the heating water system to the heat pump, the heating system must be flushed to remove any impurities, residue from sealants, etc., and to prevent any accumulation of deposits in the liquifier. A contaminated liquifier may cause the heat pump to completely break down. For systems in which the heating water flow can be shut off via the radiator or thermostat valves, an overflow valve must be installed in a heating bypass downstream from the heat pump by the customer. This ensures a minimum heating water flow rate through the heat pump and helps to avoid faults.

Once the heating system has been installed, it must be filled, de-aerated and pressure-tested (in the heat pump the air-relief cock is located at or in the water pipes at the condenser).

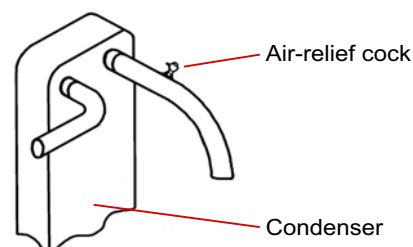

Minimum heating water flow rate

The minimum heating water flow rate through the heat pump must be assured in all operating states of the heating system. This can be accomplished, for example, by installing either a manifold without differential pressure or an overflow valve. The procedure for adjusting an overflow valve is described in the Chapter Start-up.

Antifreeze

Manual drainage should be provided for heat pumps which are exposed to frost. The antifreeze function of the heat pump controller is active whenever the controller and the heat circulating pump are ready for operation. If the heat pump is taken out of service or in the event of a power failure, the system has to be drained, and if required, blown out, at three locations (see illustration). The heating circuit should be operated with a suitable antifreeze if heat pump systems are implemented in buildings where a power failure can not be detected (holiday home).

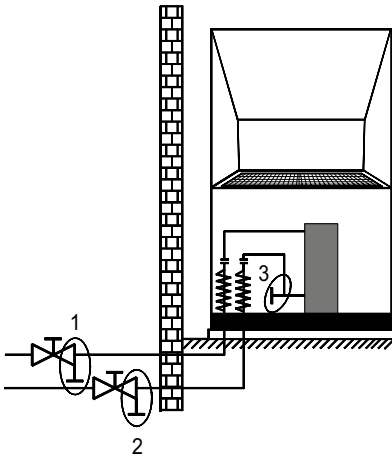

6.3 Electrical Connection

A standard four-core cable is used for connecting the heat pump to the power supply.

The power supply and the control line are normally installed in the ground (in ductwork with a suitable size and resistance) and routed from the heat pump to the building. This ductwork must extend into the heat pump by approx. 22 mm and be installed with a continuous downward slope in order to comply with Section 42 of the VDE 0100 regulations. Instead of 90° bends, two 45° bends must be used as pipe bends. The control line and the cable for the power supply are drawn into this ductwork.

The cable (power supply) must be provided by the customer. The conductor cross section is selected in accordance with the power consumption of the heat pump (see Appendix Device Information) and the applicable VDE (EN) and VNB regulations.

The power supply line on the heat pump must be fed through the provided cable feedthrough into the switch box. The line must be firmly screwed to its feedthrough (vapour sealed pipe union).

An all-pole disconnecting device with a contact gap of at least 3 mm (e.g. utility blocking contactor or power contactor) as well as a 3-pole circuit breaker with common tripping for all external conductors must be installed in the power supply (tripping current in compliance with the Device Information). Ensure that the incoming supply has a clockwise rotating field when connecting multiphase devices.

Phase sequence: L1, L2, L3.

⚠ ATTENTION!

Ensure that there is a clockwise rotating field: Operating the compressor in the wrong rotational direction could cause damage to the compressor.

The control voltage is supplied via the heat pump controller.

The heat pump controller has a 230 V AC-50 Hz power supply. Connect the controller in compliance with its own operating instructions (16 A fuse).

The control line (not included in scope of supply) is connected to the heat pump controller using the two rectangular plug connectors. Use the plug connector located on the base of the heat pump adjacent to the cable gland in the base plate. More detailed information can be found in the operating instructions of the heat pump controller.

For detailed information, see Circuit Diagrams in the Appendix.

7 Start-up

7.1 General Information

To ensure that start-up is performed correctly, it should only be carried out by an after-sales service technician authorised by the manufacturer. This may be a condition for extending the guarantee (see Warranty Service).

7.2 Preparation

The following items need to be checked prior to start-up:

- The heat pump must be fully connected, as described in Chapter 6.
- All valves that could impair the proper flow of the heating water in the heating circuit must be open.
- The air intake and air outlet paths must be clear.
- The ventilator must turn in the direction indicated by the arrow.
- The settings of the heat pump controller must be adapted to the heating system in accordance with the controller's operating instructions.
- Ensure the condensate outflow functions.

7.3 Procedure

The heat pump is started up via the heat pump controller. Adjustments should be made in compliance with the instructions.

If an overflow valve is fitted to maintain the minimum heating water flow rate, the valve must be adapted to the requirements of the heating system. Incorrect adjustment can lead to faulty operation and increased energy consumption. We recommend carrying out the following procedure to correctly adjust the overflow valve:

Close all of the heating circuits that may also be closed during operation (depending on the type of heat pump usage) so that the most unfavourable operating state - with respect to the water flow rate - is achieved. This normally means the heating circuits of the rooms on the south and west sides of the building. At least one heating circuit must remain open (e.g. bathroom).

The overflow valve should be opened far enough to produce the maximum temperature spread between the heating flow and return flow listed in the following table for the current heat source temperature. The temperature spread should be measured as close as possible to the heat pump. The heating element of mono energy systems should be disconnected.

Heat source temperature		Max. temperature spread between heating flow and return flow
From	To	
-20 °C	-15 °C	4 K
-14 °C	-10 °C	5 K
-9 °C	-5 °C	6 K
-4 °C	0 °C	7 K
1 °C	5 °C	8 K
6 °C	10 °C	9 K
11 °C	15 °C	10 K
16 °C	20 °C	11 K
21 °C	25 °C	12 K
26 °C	30 °C	13 K
31 °C	35 °C	14 K

Any faults occurring during operation are also displayed on the heat pump controller and can be corrected as described in the operating instructions of the heat pump controller.

For external temperatures below 10 °C and heating water temperatures below 16 °C, the buffer tank should be heated up with the second heat generator to at least 25 °C.

Observe the following procedure to implement a smooth start-up:

- 1) Close all of the heating circuits.
- 2) Fully open the overflow valve.
- 3) Use the controller to select the automatic operating mode.
- 4) Wait until the buffer tank has reached a temperature of at least 25 °C.
- 5) Now slowly reopen the heating circuit valves in succession so that the heating water throughput is constantly raised by slightly opening the respective heating circuit. The heating water temperature in the buffer tank must not be allowed to drop below 20 °C during this process. This ensures that the heat pump can be defrosted at any time.
- 6) Set the minimum volume flow quantity on the overflow valve and heat circulating pump when all heating circuits are fully open and a heating water temperature in the buffer tank of approx. 20 °C is maintained.
- 7) New buildings have an increased heat consumption on account of the energy required to dry them out. This increased heat consumption means that marginally dimensioned heating systems can not always achieve the desired room temperature. In such cases, we recommend keeping a second heat generator on standby during the first heating period. The limit temperature on the heat pump controller should also be turned up to 15 °C.

8 Maintenance / Cleaning

8.1 Maintenance

To protect the paintwork, avoid leaning anything against the device or putting objects on the device. External heat pump parts can be wiped with a damp cloth and domestic cleaner.

⚠ ATTENTION!

Never use cleaning agents containing sand, soda, acid or chloride as these can damage the surfaces.

To prevent faults due to sediment in the heat exchanger of the heat pump, ensure that the heat exchanger in the heating system can not be contaminated. In the event that operating malfunctions due to contamination still occur, the system should be cleaned as described below. The device may only be cleaned according to the following instructions from the manufacturer.

8.2 Cleaning the Heating System

The ingress of oxygen into the heating water circuit may result in the formation of oxidation products (rust), particularly if steel components are used. These products enter the heating system via the valves, the circulating pumps and/or plastic pipes. It is therefore essential - in particular with respect to the piping of underfloor heating systems - that only diffusion-proof materials are used.

⚠ ATTENTION!

We recommend the installation of a suitable corrosion protection system to prevent the formation of deposits (e.g. rust) in the condenser of the heat pump.

Residue from lubricants and sealants may also contaminate the heating water.

In the case of severe contamination leading to a reduction in the performance of the liquifier in the heat pump, the system must be cleaned by a heating technician.

According to today's state of knowledge, we recommend using a 5 % phosphoric acid solution for cleaning purposes. However, if cleaning needs to be performed more frequently, a 5 % formic acid solution should be used.

In either case, the cleaning fluid should be at room temperature. We recommend flushing the heat exchanger in the direction opposite to the normal flow direction.

To prevent acidic cleaning agents from entering the heating system circuit, we recommend connecting the flushing device directly to the flow and return flow of the liquifier of the heat pump.

It is important that the system be thoroughly flushed using appropriate neutralising agents to prevent any damage from being caused by cleaning agent residue remaining in the system.

Acids must be used with great care and all relevant regulations of the employers' liability insurance associations must be adhered to.

If in doubt, contact the manufacturer of the chemicals!

8.3 Cleaning the Air System

Evaporator, ventilator and condensate outflow should be cleaned of contamination (leaves, twigs, etc.) before each new heating period.

Do this by opening the front of the heat pump. The bottom should be opened first followed by the top.

⚠ ATTENTION!

Before opening the device, ensure that all circuits are isolated from the power supply.

Remove and rehang the side panel assemblies as described in Chapter 4.

To prevent the evaporator and the condensate tray from being damaged, do not use hard or sharp objects for cleaning.

⚠ ATTENTION!

The refrigerating circuit may not be damaged in any way.

Inflammable refrigerant could leak out if the refrigerating circuit is damaged. Ignition sources and open flames must be avoided when carrying out any work on the device.

Under extreme weather conditions (e.g. snow drifts), ice may form on the air intake and exhaust air outlet grids. If this happens, the ice must be removed in the vicinity of the air intake and exhaust air outlet grids to ensure that the minimum air flow rate is maintained.

9 Faults / Trouble-Shooting

This heat pump is a quality product and is designed for trouble-free and maintenance-free operation. In the event that a fault should occur, it will be indicated on the heat pump manager display. Simply consult the Faults and Trouble-shooting page in the operating instructions of the heat pump manager. If you cannot correct the fault yourself, please contact your after-sales service technician.

⚠ ATTENTION!

Any work on the heat pump may only be performed by authorised and qualified after-sales service technicians.

Anyone carrying out work on the refrigerating circuit must be certified to safely handle inflammable refrigerants or be supervised by a person having such certification.

10 Decommissioning/ Disposal

Before removing the heat pump, disconnect it from the power source and close all valves. Observe all environmentally-relevant requirements regarding the recovery, recycling and disposal of materials and components in accordance with all applicable standards. Particular attention should be paid to the proper disposal of refrigerants and refrigeration oils.

11 Device Information

1 Type and order code	LA 17PS	LA 22PS	LA 26PS			
2 Design						
2.1 Degree of protection according to EN 60 529 for compact devices and heating components	IP 24	IP 24	IP 24			
2.2 Installation Location	Outdoors	Outdoors	Outdoors			
3 Performance data						
3.1 Operating temperature limits:						
Heating water flow/return flow ¹	°C / °C	Up to 65 / above 18	Up to 65 / above 18			
Air	°C	-20 to +35	-20 to +35			
3.2 Temperature spread of heating water at A7 / W35	9.3 5.0	9.5 5.0	9.4 5.0			
3.3 Heat output / COP	at A-7 / W35 ²	kW / ---	3	6.7 / 2.5 6.4 / 2.4	7.7 / 2.4 7.5 / 2.3	8.7 / 2.4 8.4 / 2.2
			4	11.4 / 2.6 10.8 / 2.5	13.6 / 2.6 13.1 / 2.5	14.4 / 2.6 13.9 / 2.5
	at A-7 / W45 ²	kW / ---	3		7.0 / 2.2	7.8 / 2.3
			4	10.3 / 2.2	12.5 / 2.3	13.3 / 2.3
	at A2 / W35 ²	kW / ---	3	8.7 / 3.2 8.3 / 3.0	10.6 / 3.1 10.5 / 3.0	11.7 / 3.1 11.5 / 3.0
			4	14.5 / 3.1 14.3 / 3.0	16.7 / 3.1 16.5 / 3.0	18.8 / 3.1 18.6 / 3.0
	at A7 / W35 ²	kW / ---	3	10.1 / 3.6 9.6 / 3.4	12.6 / 3.8 12.0 / 3.6	13.7 / 3.6 13.3 / 3.5
			4	17.3 / 3.5 16.6 / 3.4	22.0 / 3.8 21.1 / 3.5	24.0 / 3.7 22.9 / 3.5
	at A7 / W45 ²	kW / ---	3		9.3 / 2.9	11.3 / 3.0
			4	16.1 / 2.9	20.5 / 3.0	21.6 / 3.0
	at A10 / W35 ²	kW / ---	3	11.8 / 4.1 11.4 / 4.1	13.7 / 4.2 13.5 / 4.1	15.0 / 4.1 14.7 / 4.0
			4	19.6 / 3.8 19.2 / 3.8	23.4 / 4.0 23.2 / 3.9	26.2 / 4.0 25.9 / 4.0
3.4 Sound power level	dB(A)	64	68			
3.5 Sound pressure level at a distance of 10 m (air outlet side) dB(A)		37	41			
3.6 Heating water flow with an internal pressure differential of m ³ /h / Pa		1.6 / 2900 3.0 / 10000	2.0 / 4500 3.5 / 13800			
3.7 Air flow rate	m ³ /h	5500	8000			
3.8 Refrigerant; total filling weight	type / kg	R290 / 1.8	R290 / 2.2			
4 Dimensions, connections and weight						
4.1 Device dimensions	H x W x L cm	157 x 155 x 85	171 x 168 x 100			
4.2 Device connections to heating system	Inch	G 1 1/4" external	G 1 1/4" external			
4.3 Weight of the transportable unit(s) incl. packing	kg	330	371			
5 Electrical connection						
5.1 Nominal voltage; fuse protection	V / A	400 / 20 T	400 / 20 T			
5.2 Nominal power consumption ²	A2 W35	kW	4.74 4.76			
5.3 Starting current with soft starter	A	23	25			
5.4 Nominal current A2 W35 / cos φ	A / ---	8.6 / 0.8 8.6 / 0.8	9.8 / 0.8 9.9 / 0.8			
6 Complies with the European safety regulations		5	5			
7 Additional model features						
7.1 Defrosting		Automatic	Automatic			
Type of defrosting		Hot gas	Hot gas			
Defrosting tray included		Yes (heated)	Yes (heated)			
7.2 Heating water in device protected against icing ⁶		Yes	Yes			
7.3 Performance levels		2	2			
7.4 Controller internal/external		External	External			

1. See operating limits diagram

2. This data indicates the size and capacity of the system. For an analysis of the economic and energy efficiency of the system, other parameters, such as, in particular, the defrosting capacity, the bivalence point and regulation, should also be taken into consideration. The specified values, e.g. A2 / W55, have the following meaning: 2 °C external air temperature and 55 °C heating water flow temperature.

3. Operation with 1 compressors

4. Operation with 2 compressors

5. See CE declaration of conformity

6. The heat circulating pump and the heat pump controller must always be ready for operation.

Anhang / Appendix / Annexes

1	Maßbild / Dimension Drawing / Schéma coté	A-II
1.1	Maßbild / Dimension Drawing / Schéma coté LA 17PS.....	A-II
1.2	Maßbild / Dimension Drawing / Schéma coté LA 22PS - LA 26PS	A-III
2	Diagramme / Diagrams / Diagrammes.....	A-IV
2.1	Kennlinien / Characteristic Curves / Courbes caractéristiques LA 17PS.....	A-IV
2.2	Kennlinien / Characteristic Curves / Courbes caractéristiques LA 22PS.....	A-V
2.3	Kennlinien / Characteristic Curves / Courbes caractéristiques LA 26PS.....	A-VI
3	Stromlaufpläne / Circuit Diagrams / Schémas électriques.....	A-VII
3.1	Steuerung / Control / Commande	A-VII
3.2	Last / Load / Charge	A-VIII
3.3	Anschlussplan / Circuit Diagram / Schéma électrique	A-IX
3.4	Legende / Legend / Légende.....	A-X
4	Hydraulische Prinzipschemen / Hydraulic Plumbing Diagram / Schémas hydrauliques	A-XI
4.1	Monoenergetische Anlage / Mono Energy System / Installation monoénergétique	A-XI
4.2	Monoenergetische Anlage und Warmwasserbereitung / Mono Energy System and Domestic Hot Water Preparation / Installation monoénergétique et production d'eau chaude.....	A-XII
4.3	Bivalente Anlage / Bivalent System / Installation bivalente	A-XIII
4.4	Legende / Legend / Légende.....	A-XIV
5	Konformitätserklärung / Declaration of Conformity / Déclaration de conformité	A-XV

1.2 Maßbild / Dimension Drawing / Schéma coté LA 22PS - LA 26PS

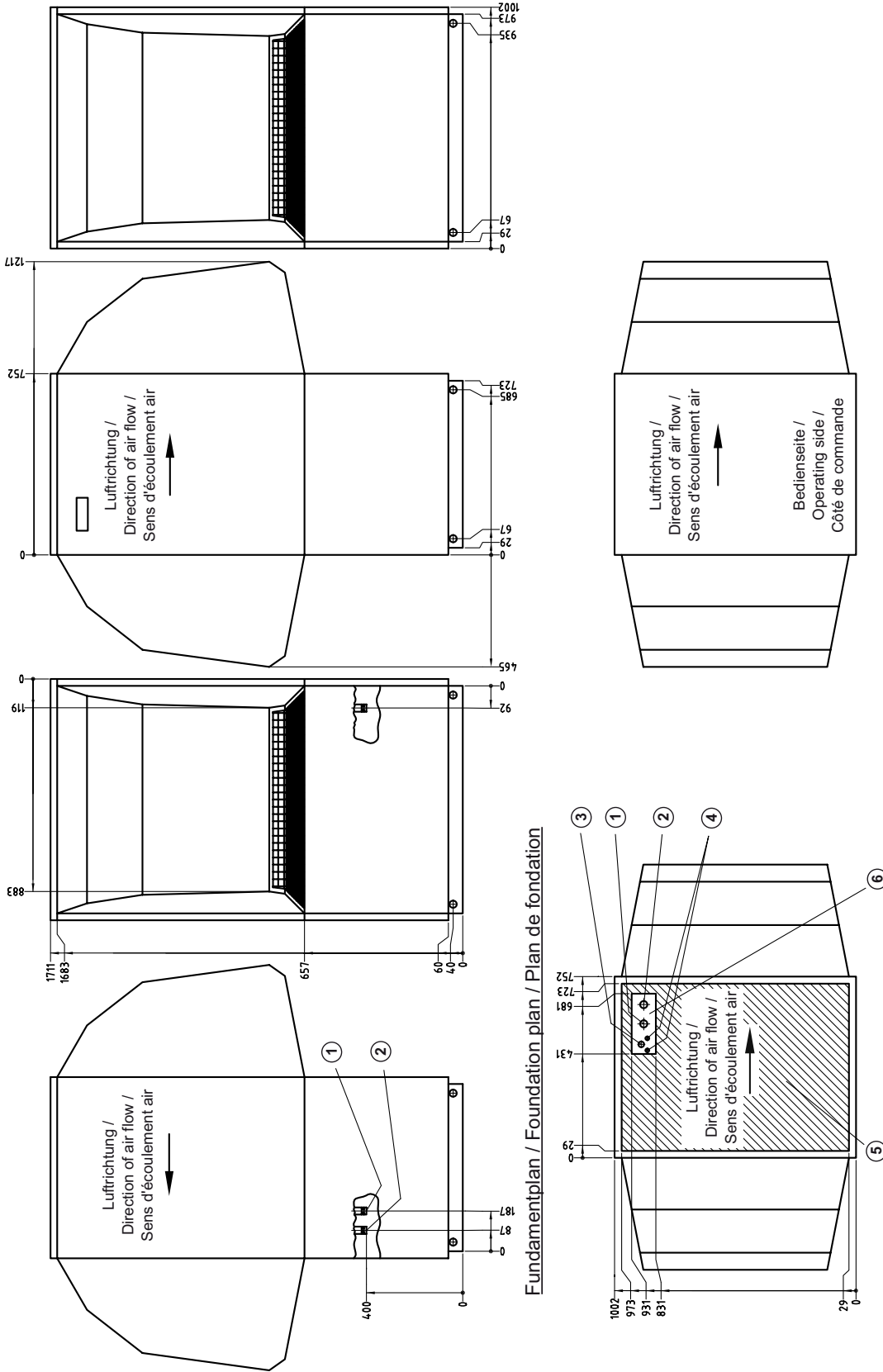

	Elektroleitungen	Electric lines	Lignes électriques
④	Heizungsrücklauf Eingang in die WP 1 1/4" Außengewinde	Heating water return flow Heat pump inlet 1 1/4" external thread	Lignes électriques Socle PAC
⑤	Heizungsvorlauf Ausgang aus der WP 1 1/4" Außengewinde	Heating water flow Heat pump outlet 1 1/4" external thread	Base of heat pump Area of openings for heating circuit, condensate drain, electrical cable
⑥	Kondensatablauf Innen ø 30 mm	Condensate outflow inside ø 30 mm	Passages circuit de chauffage, écoulement du condensat, câble électrique

2 Diagramme / Diagrams / Diagrammes

2.1 Kennlinien / Characteristic Curves / Courbes caractéristiques LA 17PS

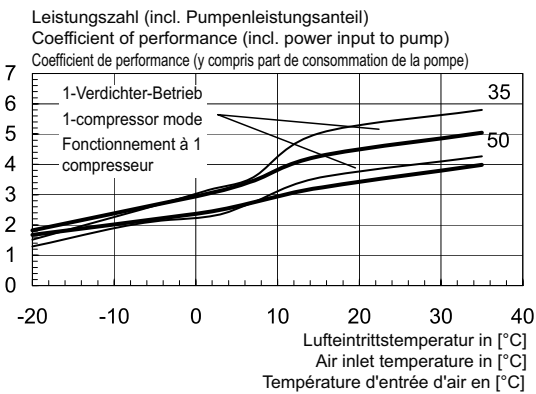
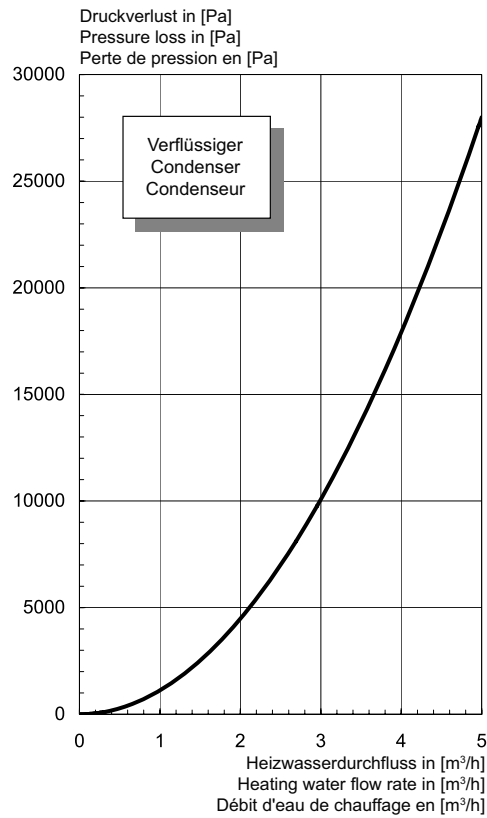
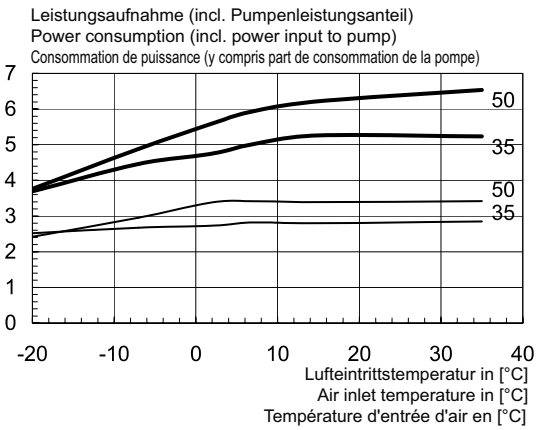
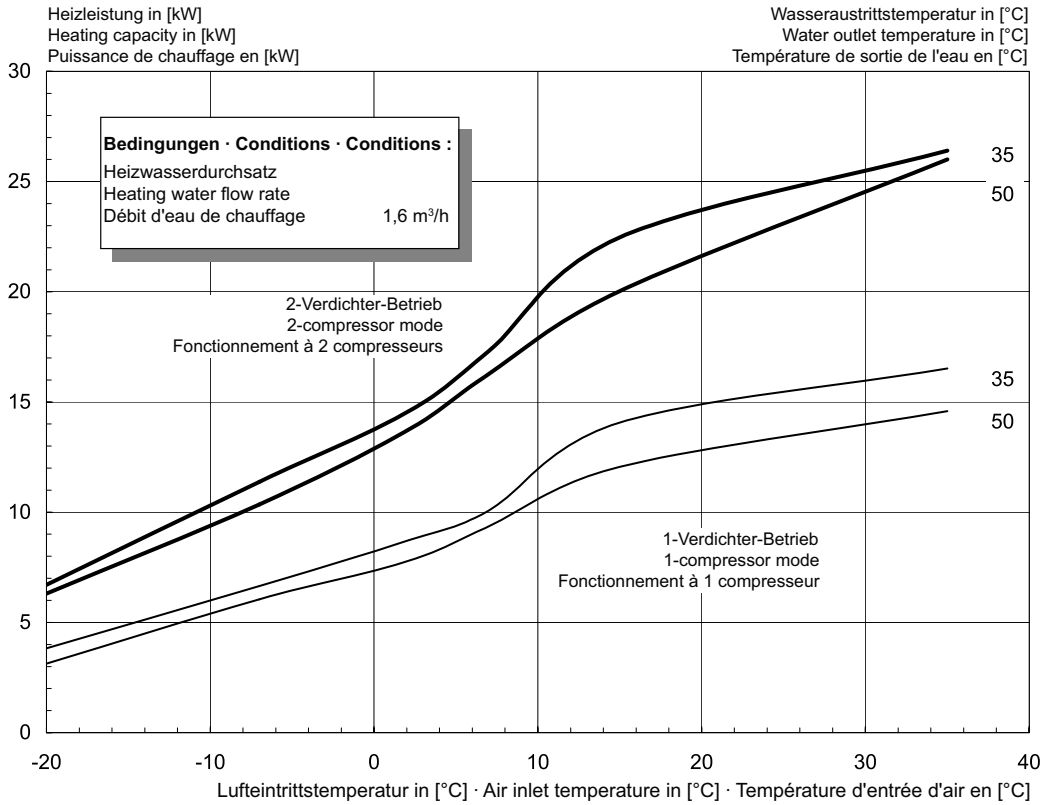

Anhang · Appendix · Annexes

2.2 Kennlinien / Characteristic Curves / Courbes caractéristiques LA 22PS

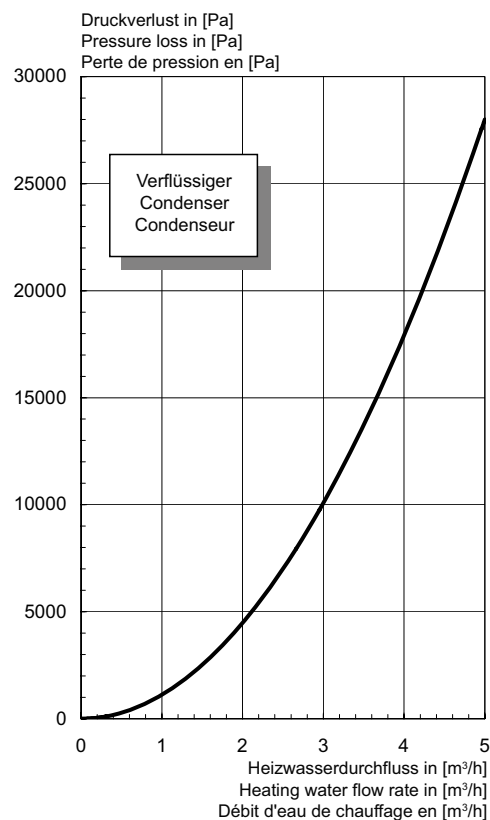
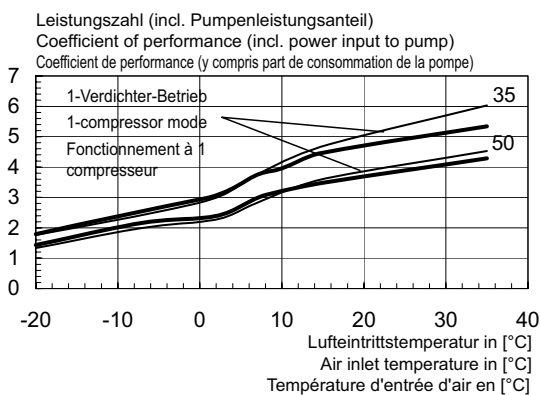
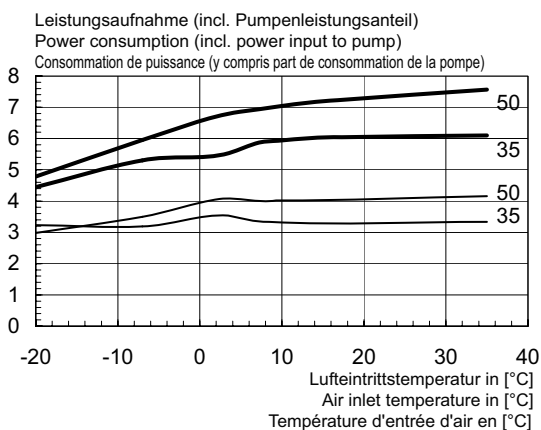
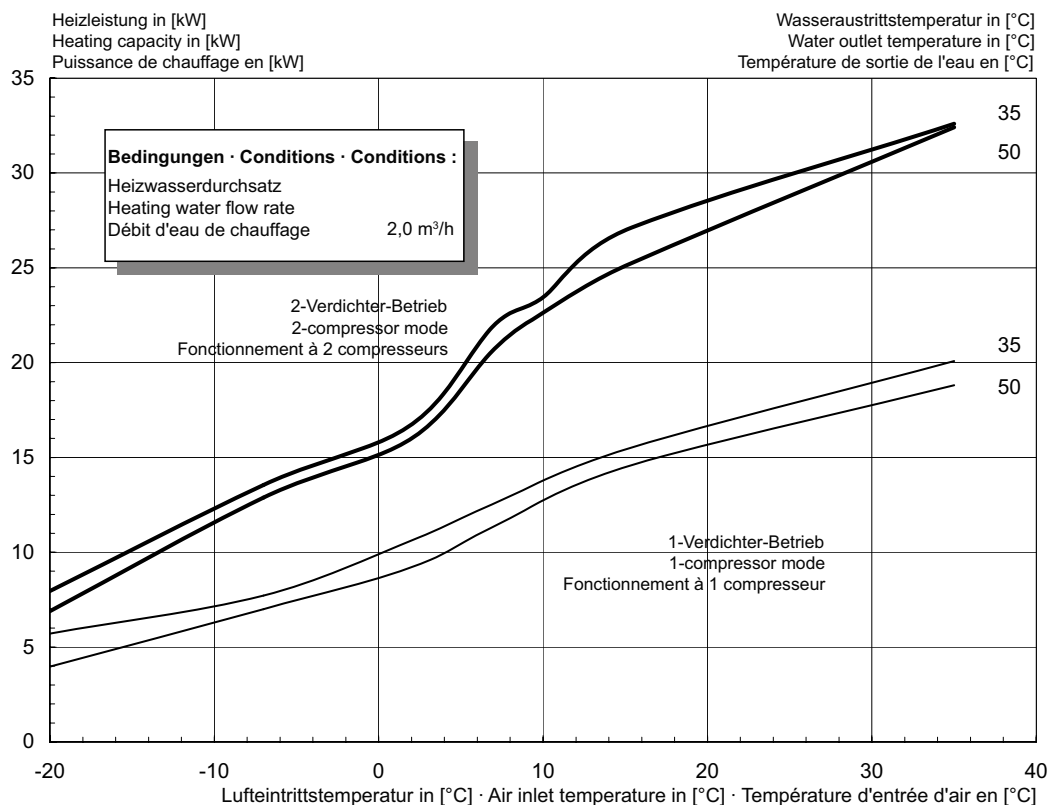

2.3 Kennlinien / Characteristic Curves / Courbes caractéristiques LA 26PS

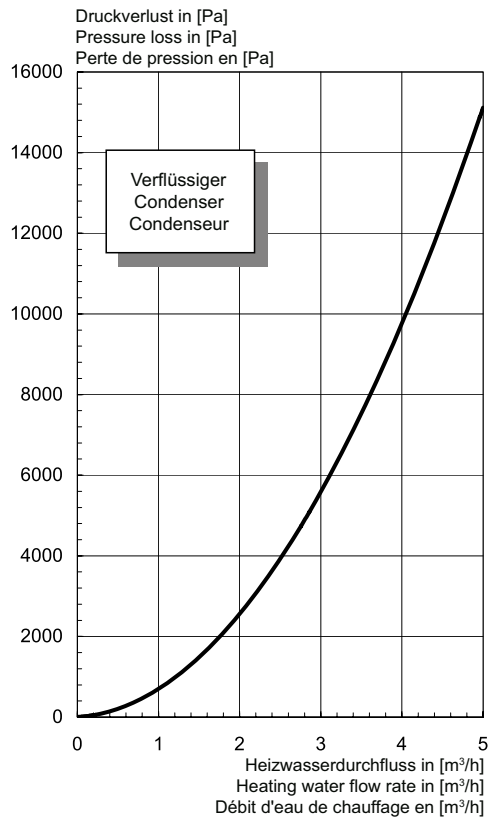
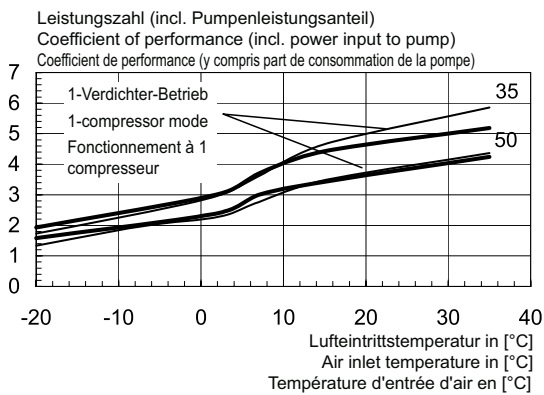
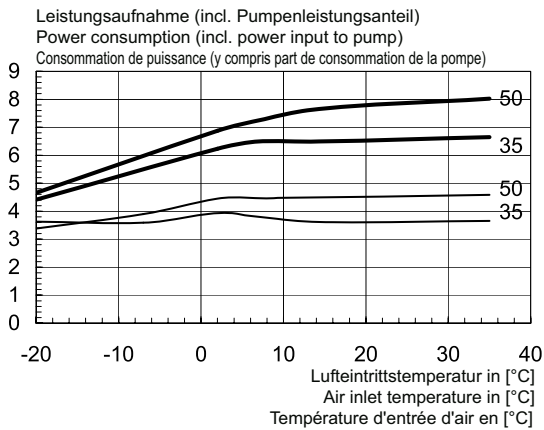
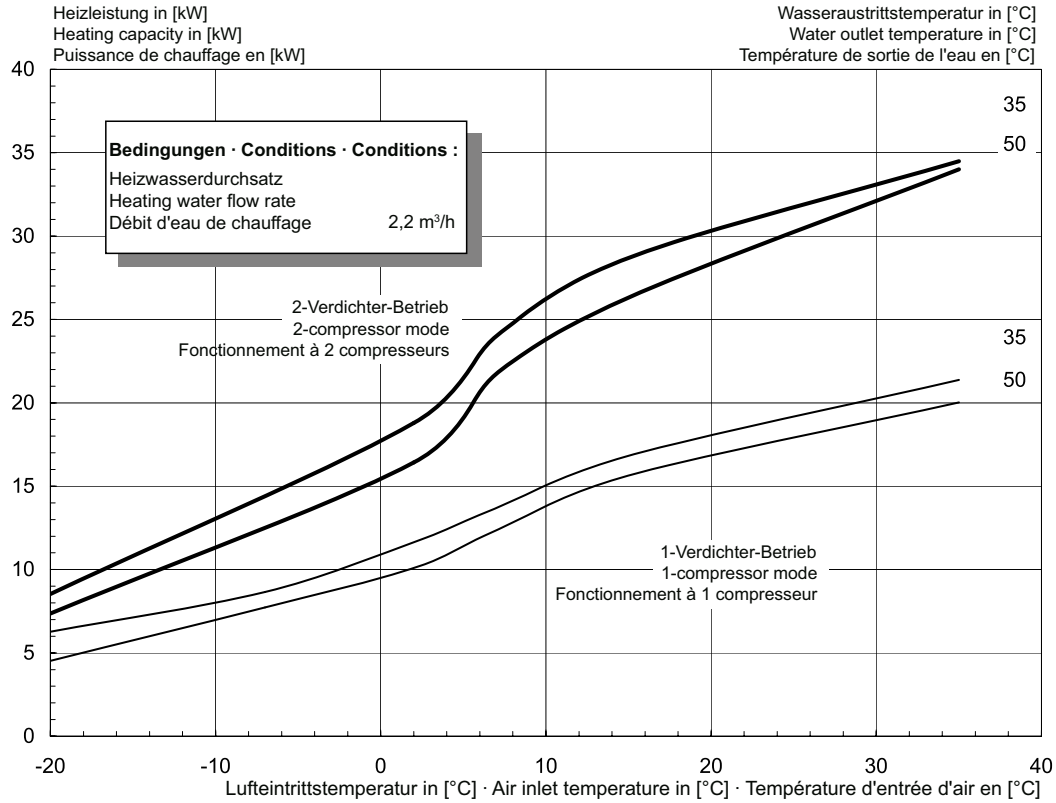

Anhang · Appendix · Annexes

3 Stromlaufpläne / Circuit Diagrams / Schémas électriques

3.1 Steuerung / Control / Commande

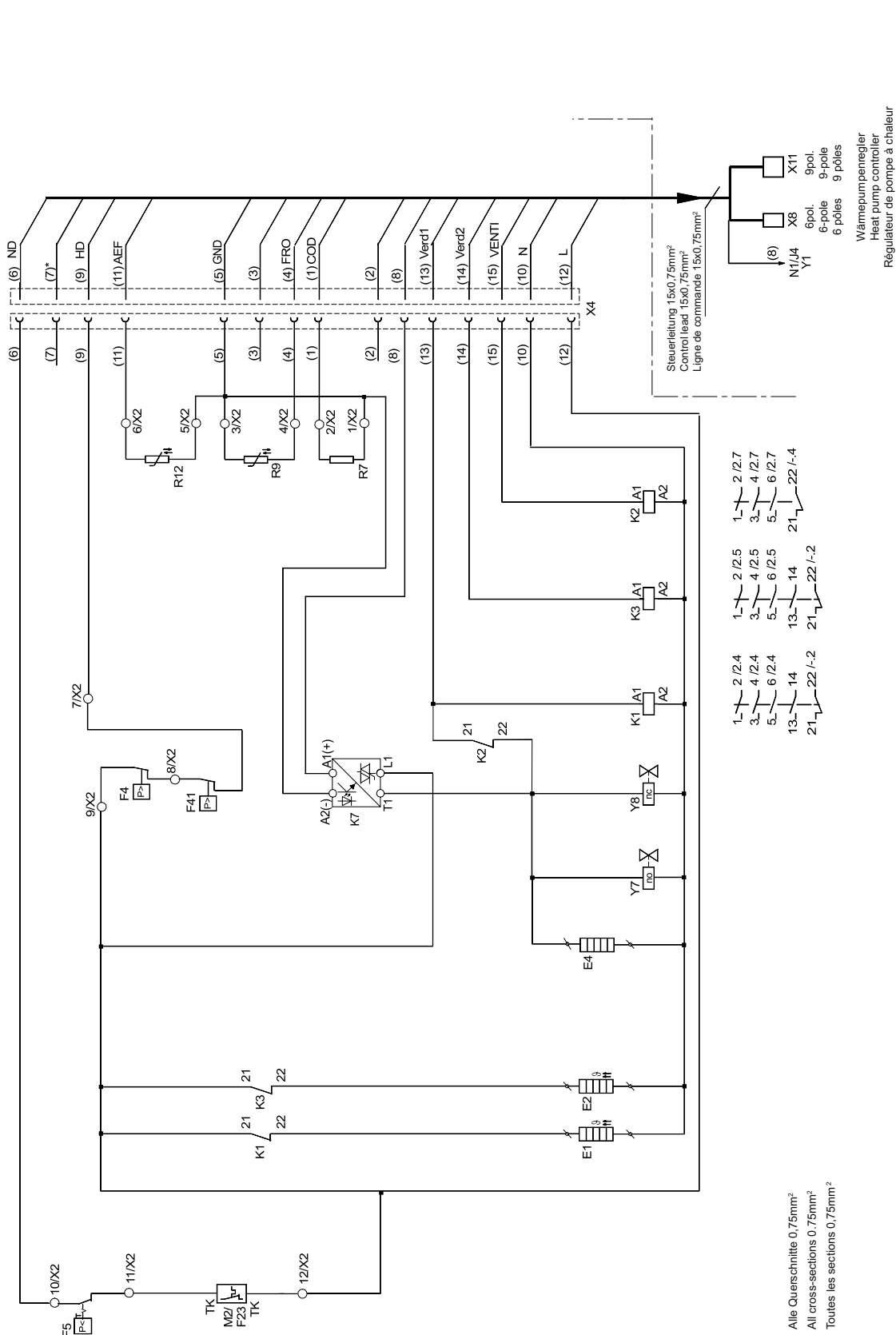

3.2 Last / Load / Charge

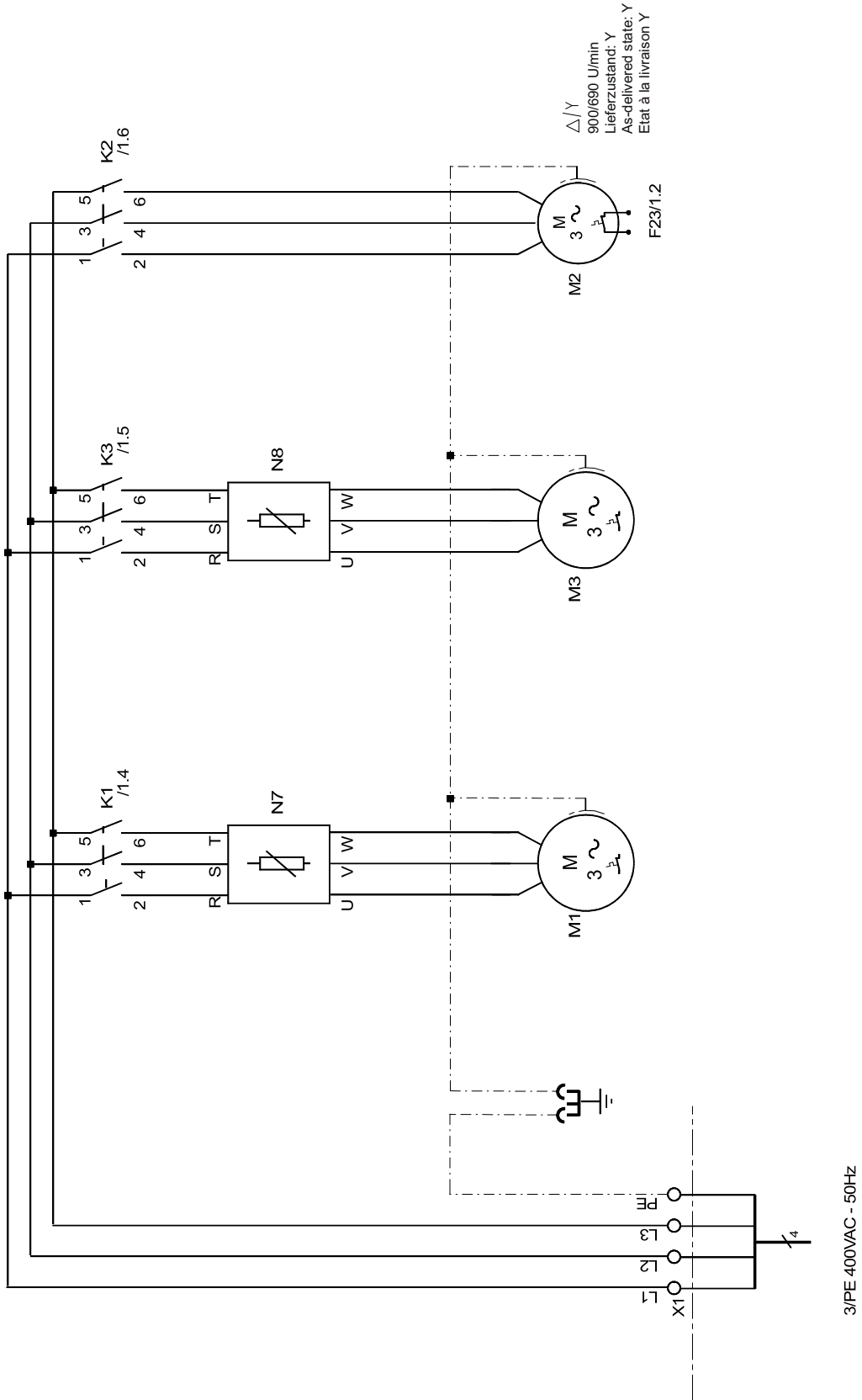

3.3 Anschlussplan / Circuit Diagram / Schéma électrique

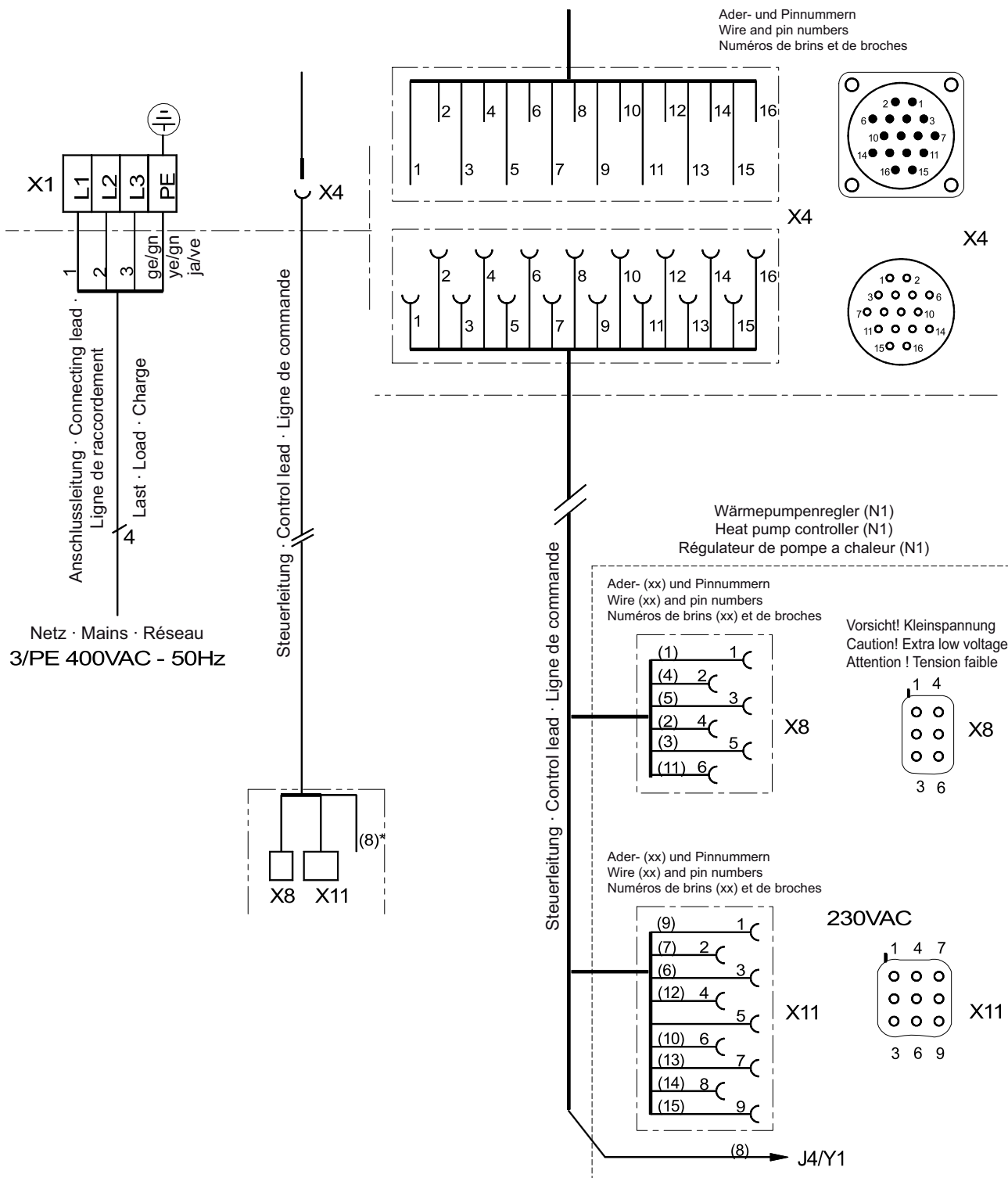

3.4 Legende / Legend / Légende

E1	Ölumpfheizung Verdichter 1	Oil sump heater for compressor 1	Chauffage à carter d'huile compresseur 1
E2	Ölumpfheizung Verdichter 2	Oil sump heater for compressor 2	Chauffage à carter d'huile compresseur 2
E4	Düsenringheizung Ventilator	Nozzle ring heater, ventilator	Chauffage à couronne perforée ventilateur
F4	Pressostat Hochdruck Verdichter 1	High-pressure switch, compressor 1	Pressostat haute pression, circuit froid 1
F5	Pressostat Niederdruck	Low-pressure switch	Pressostat basse pression
F23	Wicklungsschutz Ventilator	Winding protection, ventilator	Blindage de l'enroulement ventilateur
F41	Pressostat Hochdruck Verdichter 2	High-pressure switch, compressor 2	Pressostat haute pression, circuit froid 2
K1	Schütz Verdichter 1	Contacteur for compressor 1	Contacteur compresseur 1
K2	Schütz Ventilator	Contacteur, ventilator	Contacteur ventilateur
K3	Schütz Verdichter 2	Contacteur for compressor 2	Contacteur compresseur 2
K7	Halbleiterrelais-Abtauung	Semiconductor relay, defrosting	Dégivrage relais statique
M1	Verdichter 1	Compressor 1	Compresseur 1
M2	Ventilator	Ventilator	Ventilateur
M3	Verdichter 2	Compressor 2	Compresseur 2
N1	Wärmepumpenregler	Heat pump controller	Régulateur de pompe à chaleur
N7	Sanftanlaufsteuerung Verdichter 1	Soft start control for compressor 1	Commande de démarrage progressif compresseur 1
N8	Sanftanlaufsteuerung Verdichter 2	Soft start control for compressor 2	Commande de démarrage progressif compresseur 2
R7	Kodierwiderstand (2k7/0,25W)	Coding resistor (2k7 / 0.25 W)	Résistance de codage (2k7/0,25W)
R9	Frostschutzfühler	Flow sensor	Sonde antigel
R12	Abtauendefühler	Defrost end sensor	Sonde fin de dégivrage
X1	Klemmenleiste: Lastspeisung	Terminal strip: Incoming supply to the load	Bornier : alimentation de charge
X2	Klemmenleiste: interne Verdrahtung	Terminal strip: Internal wiring	Bornier : câblage interne
X4	Steckverbinder Steuerleitung / Wärmepumpe	Plug connector, control line/heat pump	Connecteur ligne de commande/pompe à chaleur
X8/X11	Steckverbinder Steuerleitung / Wärmepumpenregler	Plug connector, control line / Heat pump controller	Connecteur de la ligne de commande / régulateur de pompe à chaleur
Y7	Magnetventil Hauptleitung (no)	Solenoid valve, main line (no)	Electrovanne ligne principale (no)
Y8	Magnetventil Bypass (nc)	Solenoid valve, bypass (nc)	Electrovanne dérivation (nc)

4 Hydraulische Prinzipschemen / Hydraulic Plumbing Diagram / Schémas hydrauliques

4.1 Monoenergetische Anlage / Mono Energy System / Installation monoénergétique

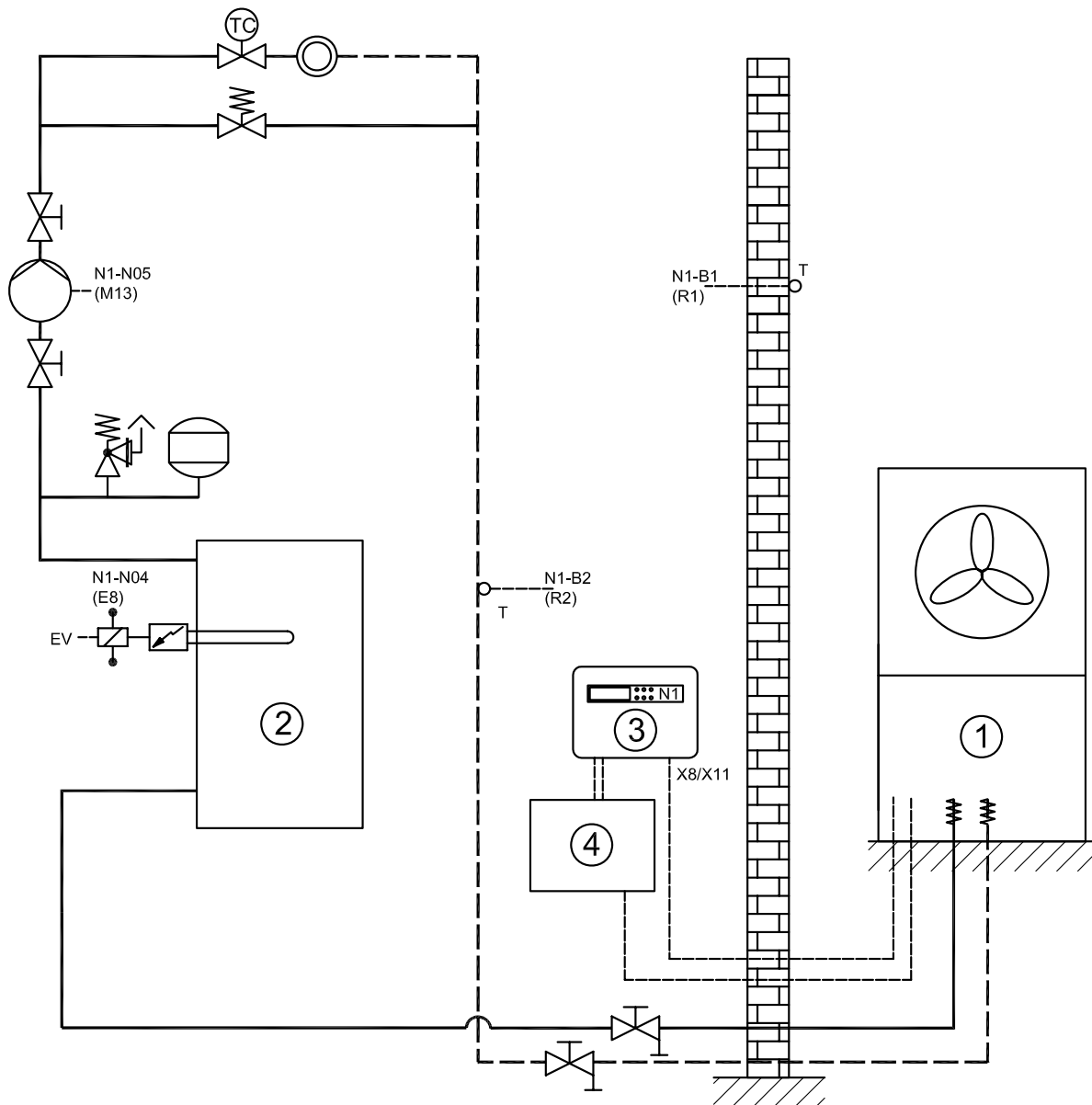

4.2 Monoenergetische Anlage und Warmwasserbereitung / Mono Energy System and Domestic Hot Water Preparation / Installation monoénergétique et production d'eau chaude

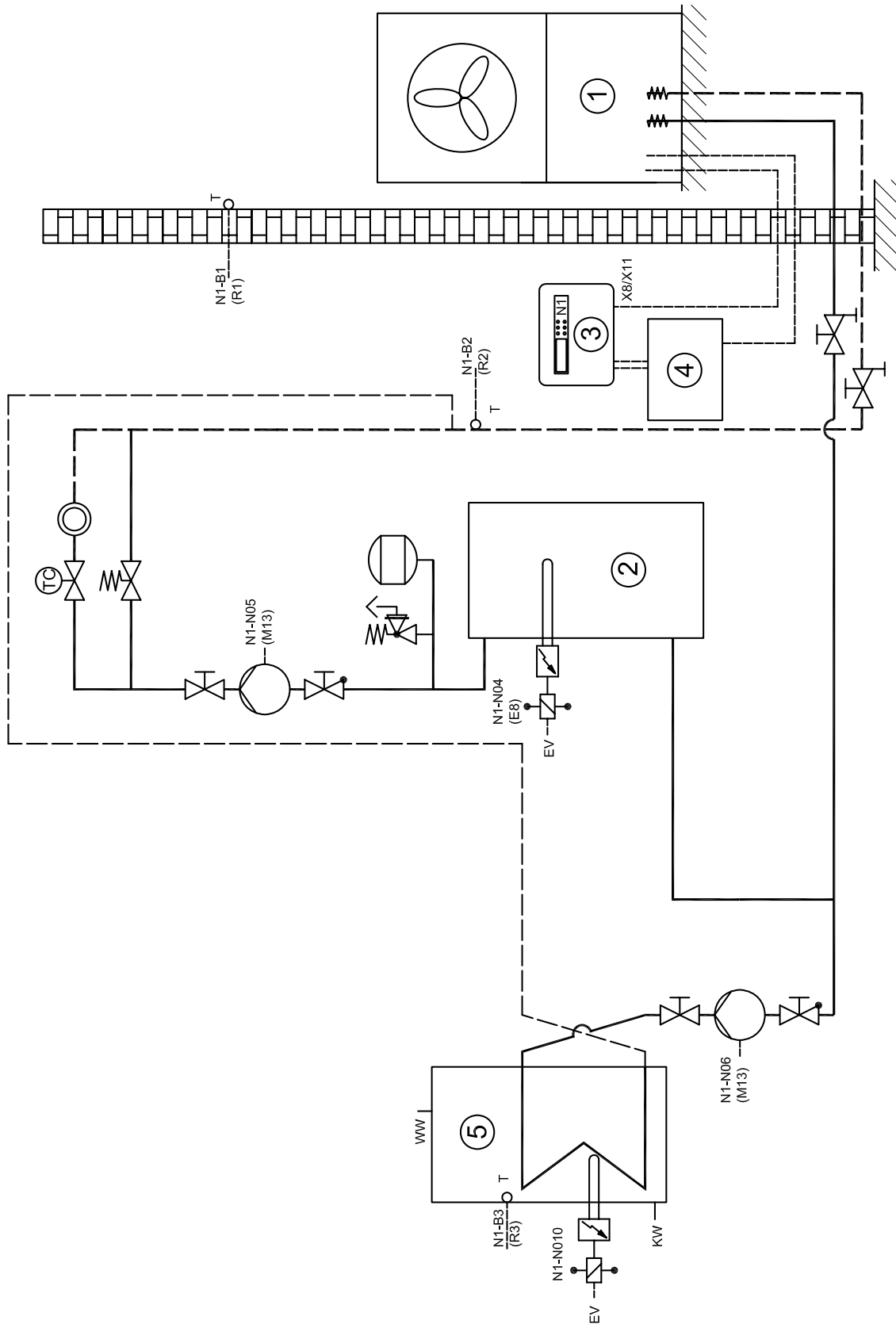

4.4 Legende / Legend / Légende

	Absperrventil	Shutoff valve	Robinet d'arrêt
	Überstromventil	Overflow valve	Vanne de trop-plein
	Sicherheitsventilkombination	Safety valve combination	Groupe de valves de sécurité
	Umwälzpumpe	Circulating pump	Circulateur
	Ausdehnungsgefäß	Expansion vessel	Vase d'expansion
	Raumtemperaturgesteuertes Ventil	Room temperature-controlled valve	Vanne commandée par température
	Absperrventil mit Rückschlagventil	Shutoff valve with check valve	Robinet d'arrêt avec clapet anti-retour
	Absperrventil mit Entwässerung	Shutoff valve with drainage	Robinet d'arrêt avec écoulement
	Wärmeverbraucher	Heat consumer	Consommateur de chaleur
	Vierwegemischer	Four-way mixer	Mélangeur 4 voies
	Temperaturfühler	Temperature sensor	Sonde de température
	Flexibler Anschlusschlauch	Flexible connection hose	Tuyau de raccord flexible
①	Wärmepumpe	Heat pump	pompe à chaleur
②	Pufferspeicher	Buffer tank	Réservoir tampon
③	Wärmepumpenregler	Heat pump controller	Régulateur de pompe à chaleur
④	Elektroverteilung	Electrical distribution system	Distributeur courant électrique
⑤	Warmwasserspeicher	Hot water cylinder	Ballon d'eau chaude
⑥	Heizkessel	Boiler	Chaudière
E8	Zusatzheizung	Supplementary heating	Chauffage d'appoint
M13	Heizungsumwälzpumpe	Heat circulating pump	Circulateur de chauffage
M18	Warmwasserumwälzpumpe	Hot water circulating pump	Circulateur d'eau chaude
N1	Wärmepumpenregler	Heat pump controller	Régulateur de pompe à chaleur
R1	Außenwandfühler	External wall sensor	Sonde de paroi extérieure
R2	Rücklauffühler	Return flow sensor	Sonde de retour
R3	Warmwasserfühler	Hot water sensor	Sonde d'eau chaude
EV	Elektroverteilung	Electrical distribution system	Distributeur courant électrique
KW	Kaltwasser	Cold water	eau froide
MA	Mischer AUF	Mixer OPEN	Mélangeur OUVERT
MZ	Mischer ZU	Mixer CLOSED	Mélangeur FERME
WW	Warmwasser	Domestic hot water	Eau chaude

5 Konformitätserklärung / Declaration of Conformity / Déclaration de conformité

CE EG - Konformitätserklärung EC Declaration of Conformity Déclaration de conformité CE ©

Der Unterzeichnete
The undersigned
La société soussignée,

Glen Dimplex Deutschland GmbH
Geschäftsbereich Dimplex
Am Goldenen Feld 18
D - 95326 Kulmbach

bestätigt, dass das (die) nachfolgend be-
zeichnete(n) Gerät(e) aufgrund seiner (ihrer)
Konzipierung und Bauart sowie in der von
uns in Verkehr gebrachten Ausführung den
einschlägigen grundlegenden Anforderungen
der EG-Richtlinien entspricht (entsprechen).

Bei einer nicht mit uns abgestimmten
Änderung des (der) Gerät(e)s verliert
diese Erklärung ihre Gültigkeit.

hereby confirm that the design and con-
struction of the product(s) listed below,
in the version(s) placed on the market by
us, conform to the relevant requirements
of the applicable EC directives.

This declaration becomes invalidated
if any modifications are made to
the product(s) without our prior
authorisation.

certifie que l'appareil / les appareils ci-
après, par leur conception et leur mode de
construction ainsi que par la définition
technique avec laquelle il(s) sont mis en
circulation par notre société, est / sont
conforme(s) aux directives fondamentales
CEE afférentes.

Ce certificat perd sa validité pour tout
appareil modifié sans notre consentement.

Bezeichnung / Designation / Désignation

Luft/Wasser-Wärmepumpen
für Außenaufstellung mit R290
Air-to-water heat pumps
for outdoor installation, containing R290
Pompes à chaleur eau air/eau
pour installation extérieure avec R290

EG - Richtlinien / EC Directives / Directives CEE

EG-Niederspannungsrichtlinie / EC Low Voltage Directive /
Directive CEE relative à la basse tension (73/23/EWG)
EG-EMV-Richtlinie / EC EMC Directive / Directive CEE
relative à la compatibilité électromagnétique (89/336/EWG)
Druckgeräterichtlinie / Pressure Equipment Directive /
Directive CEE relative aux appareils sous pression (97/23/EG)

Typ(e):

Harmonisierte EN / Harmonized EB Standards / Normes EN harmonisées:

LA 11PS	EN 255:1997	
LA 17PS	EN 378:2000	
LA 22PS	DIN 8901	
LA 26PS	DIN EN 60335-1 (VDE 0700 T1):2005-07	EN 60335-1:2002+A11:2004+A1:2004
	DIN EN 60335-2-40 (VDE 0700 T40):2004-03	EN 60335-2-40:2003
	DIN EN 55014-1 (VDE 0875 T14-1):2003-09	EN 55014-1:2000+A1:2001+A2:2002
	DIN EN 55014-2 (VDE 0875 T14-2):2002-08	EN 55014-2:1997+A1:2001
	DIN EN 61000-3-2 (VDE 0838 T2):2001-12	EN 61000-3-2:2000
	DIN EN 61000-3-3 (VDE 0838 T3):2002-05	EN 61000-3-3:1995+Corr.:1997+A1:2001

Nationale Richtlinien / National Directives / Directives nationales

<u>D</u>	<u>A</u>	<u>CH</u>
VBG20		SVTI

Kulmbach, 10.01.2007
CE03W01E.doc

Wolfgang Weinhold
Geschäftsführer / Managing Director

Andreas Tich
Spartenleiter / Head of business unit

